

\*\*\*\*\*

# THURLBY DSA524

DIGITAL STORAGE ADAPTOR

SERVICE MANUAL

\*\*\*\*\*

## INDEX

Section

- |    |                         |
|----|-------------------------|
| 1. | Introduction.           |
| 2. | Operating Instructions. |
| 3. | Specifications.         |
| 4. | Dismantling.            |
| 5. | Circuit Descriptions.   |
| 6. | Circuit Diagrams.       |
| 7. | Component Layouts.      |
| 8. | Electrical Parts Lists. |
| 9. | Calibration Procedure.  |

## 1. INTRODUCTION

This manual is intended to assist skilled personnel in the maintenance and repair of the instruments type DSA 524/511.

Knowledge of electronic theory and practice, and access to precision test equipment is assumed.

The instrument should only be dismantled if absolutely necessary.

Repair or maintenance work carried out inexpertly will void the guarantee.

## 2. OPERATING INSTRUCTIONS:

Refer to operating manual.

## 3. SPECIFICATION:

Refer to operating manual.

## 4. DISMANTLING THE INSTRUMENT

- a. Remove power from the DSA by removing the AC line cord.
- b. Invert the unit and pull the tilt stand into the raised position (this relieves the pressure on the front feet). Remove the four long screws that pass through the feet using a size 1 pozidriv screwdriver or similar.
- c. Turn the unit the normal way up and and carefully lever the top section of the case upwards so that it slides out of the side panel mouldings.
- d. The DSA can be completely removed from its case by sliding the front and rear panels up and out. Note that there is an earthing wire to the aluminium screen in the case lower.
- e. If the DSA is fitted with an analogue plotter board, it must be removed by removing the polarised connector, removing the two rear panel fixing screws, and unclipping the board from the nylon PCB pillar.
- f. If the DSA is fitted with an IEEE-488 interface board, this must be removed by removing the polarised connector, removing the two rear panel fixing screws, and unclipping the board from the nylon PCB pillar.
- g. The upper board is the digital PCB. To gain access to the analogue PCB, this must be unscrewed from its pillars and tilted out of the way. The analogue board is mounted below an aluminium screen which must be removed to gain access.

## 5. CIRCUIT DESCRIPTION:

### Analog Section PCB

#### Introduction

The input buffers of the DSA consist of two separate high impedance amplifiers, employing both passive and active attenuation techniques to condition the input signal to the requirements of the digital processing circuitry. The level of attenuation applied to the incoming signal is microprocessor controlled.

#### Circuit Operation

Initial attenuation of the incoming signal is achieved by switching in passive networks with relays. Attenuation of x10 is achieved by switching the input signal through a network formed by R2, R3 and C3, VC1 allows adjustment of input capacitance. To achieve attenuation of x100 the signal is passed through the network formed by R5, R6 and C5 with VC2 providing adjustment of input capacitance.

The buffer amplifier employs a F.E.T to achieve a high input impedance for the HF signal path. IC1 provides the DC signal path. C7 and R14 ensure a flat frequency response above frequencies of Mhz. R12 and R13 determine the amount of feedback injected into the circuit. Q2 provides a constant current source to F1 and the biasing of F1 is adjusted by means of PR1. Q3 is employed for impedance matching purposes.

Further attenuation levels of x2.5 and x5 are achieved with Q4 and Q5. Q4 bypasses R25 when turned on. Q5 with R28 and R26 forms a potential divider to give a further x2.5 attenuation. With Q4 turned off and Q5 turned on x5 attenuation is obtained.

IC2 is a wideband differential amplifier, this compensates for any offsets present in earlier stages by comparing the offset on the input with the offset that would be present with the input grounded (this is calculated during execution of Function 78). PR2 and R30 adjust the gain of the amplifier.

Q6,Q7,Q8 and associated components form the main amplifier with PR3 adjusting frequency response.

Further control over attenuation is provided by Q12,11 and 10 which act as potential dividers. These provide attenuation for the 5,10 and 20mV ranges respectively. Q13 controls bandwidth limiting. The resulting signal is buffered by Q14 and fed to the digital board. Q15 provides impedance matching to the trigger circuitry.

The table below shows the attenuators selected for each voltage range.

Range	1st Stage Atten x1/x10/x100	2nd Stage Atten x1/x2.5/x5	3rd Stage Atten x1/x2/x4/x10
10V	x100	x5	x1
5V	x100	x2.5	x1
2V	x100	x1	x1
1V	x10	x5	x1
0.5V	x10	x2.5	x1
0.2V	x10	x1	x1
100mV	x1	x5	x1
50mV	x1	x2.5	x1
20mV	x1	x1	x1
10mV	x1	x1	x2
5mV	x1	x1	x4
2mV	x1	x1	x10

Channel 2 is an exact copy of channel 1.

The external trigger amplifier is a simple high impedance type employing a F.E.T. and is impedance matched to the next stage with Q201. C204 and R204 are present for frequency compensation purposes.

The input fed to the trigger amplifier is determined by transistors Q204,205 and 206. For example, to feed the CH2 trig signal into the amplifier Q203 is biased on. Q202 and Q203 are impedance buffers. Q207 bypasses C208 if DC coupling is selected.

The circuit formed by Q208 and C210 ensures that the input of Q210 never goes below analog ground but enables it to float at positive voltages. High frequency rejection is achieved by Q209 and C209. Q210 amplifies the trigger signal and this is buffered by Q211 and fed to U200. U200 is a high speed comparator. This allows a trigger level to be set and compared with the incoming trigger signal.

U202,203 and 204 are serial in parallel out shift registers. The shift register data is generated by the processor and the resultant output determines attenuation levels and trigger selection for both channels. The clock for the registers is also generated by the processor.

The 50Hz signal for line triggering is initially obtained from the junction between D302 and D303 of the power supply. U200 converts this sinusoidal waveform into a pulse suitable for the triggering circuitry.

U205 sets up the data for controlling U206,207 and 211. U207 determines the final attenuation necessary for the CH1 20,10 and 5mV ranges. U211 determines the lower attenuator settings. U206 is an 8 channel analog multiplexer having three binary control inputs A,B and C. The three binary signals select 1 of 8 outputs to be connected to the input analog voltage from the digital PCB DACs. This IC together with U207 and 211 and two ladder networks, provides two channel offset voltages using sample/hold techniques.

This involves constantly shifting data out of U206, thus maintaining a charge on C225-229. This voltage is compared with VREF by U210-A to give an input voltage to U207 and by U210-C to give an input voltage to U211. The desired offset voltages can now be obtained by switching this voltage through resistors to the output amplifier. U210-B and 210-D increase the resolution of this system by providing 1.1V to R285 and R289 respectively

#### Power Supply

The power supply section provides 4 stabilised voltage rails.

Namely, +7V, -7V, +5V and -5V. All the rails except -5V are generated with series regulators employing high gain op-amps as feedback elements. The -5V rail is utilises a 7905 regulator IC.PR300 varies the +7V rail by altering the voltage to the non-inverting terminal of the comparator. The +5V rail is varied by PR301 in a similar way. The inverting terminals are fixed at VREF, VREF being generated by D309 - a bandgap precision reference diode. R309 is a bleed resistor to ensure that D309 always remains in the linear section of its operating characteristic.

#### Digital Section PCB

##### Introduction

All major functions of the DSA are controlled by the 6303RP microprocessor. This employs an 8 bit architecture and features 11 I/O parallel lines and multiplexed bussing.

The DAC/ADC used is a UVC3120. This consists of a high-speed flash type 8 bit A/D converter and R-2R type D/A with switched current sources.

##### Circuit Description

The D/A converter's reference voltage of 2V is generated by a band-gap reference diode, Z401. This is buffered by IC427a and fed to pin 25 of the UVC. The ADC clock is derived from the carry out of IC448. This is gated through IC436 and fed into U445. The ADC timing is adjusted by means of PR401 and 402. This timing is critical for the correct conversion of the applied signal. The DAC clock is generated from address line 15.

IC411,409,402 and 408 provide paging between RAMs and the EPROM. During the write cycle of the aquisition RAM, the EPROM and the display RAM (IC 414) are paged out. This circuit also ensures correct timing of the DAC clock.

The shift register clocks are generated from the CB1 line of the 6522 VIA. IC418 is supplied with a code from the processor. This decides where the shift register clock will be channelled.

The timebase frequency is generated from the 20MHz crystal oscillator formed by XL400 and IC446. This is divided down by IC449,454 and 455 to give the desired timebase. The required range is selected by U451 and U452.

Trigger delay is determined by IC429 and 432. IC429 is serially loaded with the desired delay. The incoming trigger signal clocks U432 and a carry out signal is produced when the desired count contained in IC429 is reached.

IC437, 438 and 439 form the address counter chain for the acquisition RAM. The clock for which is generated from the carry out of IC448. The ADC is isolated from the RAM by IC428. On the negative edge of the ADC clock, data is latched from the UVC to the RAM and the counters incremented.

The front panel is arranged in a matrix. The L.E.Ds are driven by SIPO shift registers IC404, 407 and 400. These in turn drive transistors and inverting buffers to pull the correct combination of lines high or low to light the desired L.E.Ds. The keys are read by IC412. This IC is controlled by the processor. The key is determined in software by comparing the input code supplied to IC412 and the output it produces. The potentiometers are read by IC416 and IC415. IC 449 is an 8 bit ADC. The incoming voltages are fed in turn into the ADC by IC416 and the code produced is read by the processor. The code applied to pins 9, 10 and 11 determine which pot is to be read.

Battery backup is achieved by the circuit formed by Q409, 410, 411 and 412. When the unit is switched off RESET is held low and 2.4V is fed to the RAMS. On switch on C402 ensures a slight delay before RESET is taken high to avoid corruption of data. Q412 ensures the chip select signal is disabled for a short time after switch on to avoid data corruption. When the unit is on the battery is charged via R410.

All baud rates except 38400 are generated by the 6522 VIA. 38400 baud is generated by IC401. When 38400 is required pin 17 of the VIA is sent high. This is buffered by IC402 which then turns on Q408 driving the CLEAR of IC401 low. All the RS232 lines are handled directly by the processor. The TXD and RTS lines are op-amp buffered and incoming data and CTS are buffered by Q414 and 413 respectively.

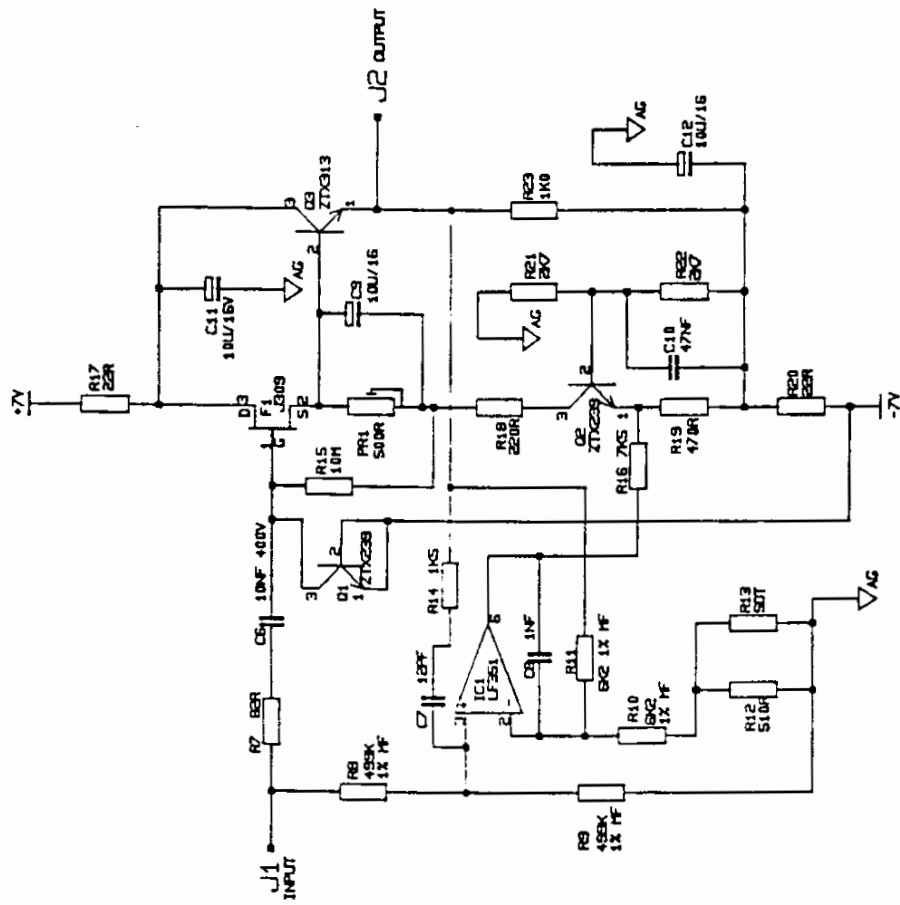

THURLBY ELECTRONICS LTD.

TITLE:

SH2. CH1 \*1 HI-Z  
BUFFER AMPLIFIER

DRAWN MR

DATE

DRAWING NO

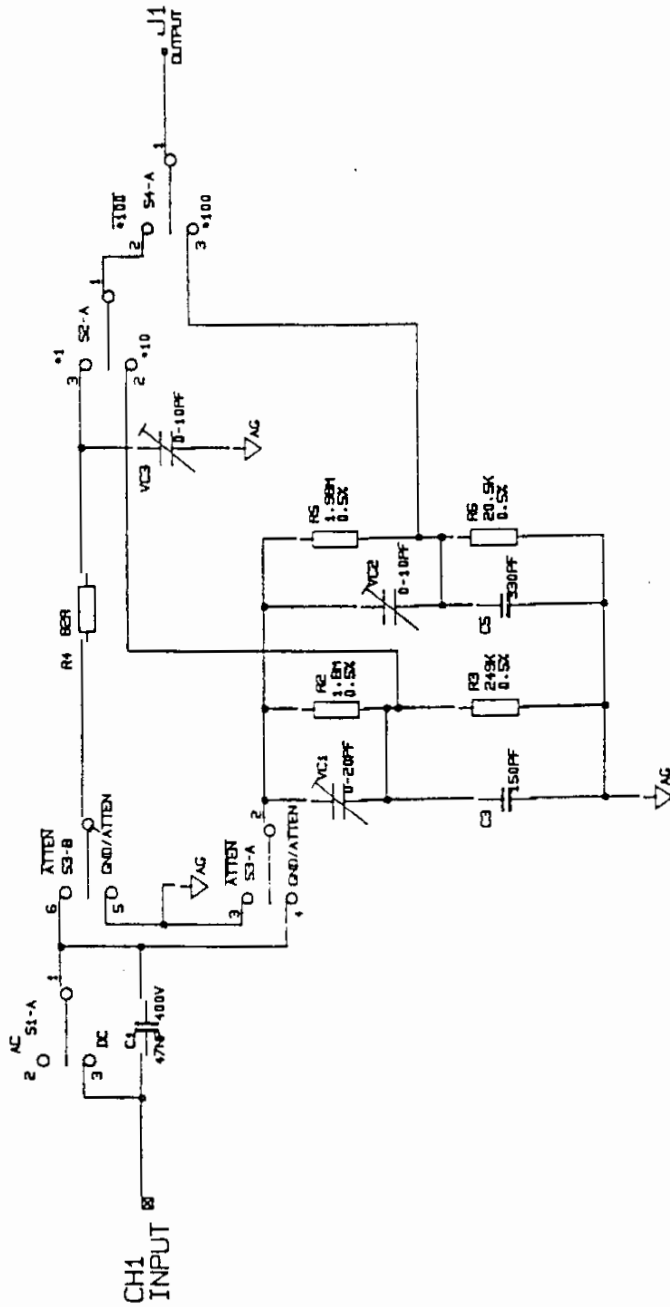

THURLBY ELECTRONICS LTD.	TITLE: SH1	DRAWN MR	DATE 1.6.87.
	CH1 INPUT ATTENUATOR	DRAWING NO	
TABLE 2. 1.10.87. IMPROVED 100 ATTENUATOR.			



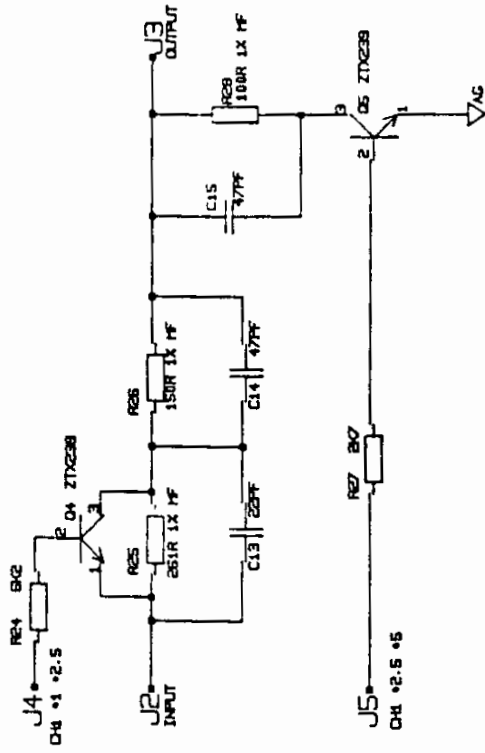

THURLBY ELECTRONICS LTD.

TITLE: SH3. CH1 \*1 \*2.5 \*5  
ATTENUATOR.

DRAWN MR DATE

DRAWING NO

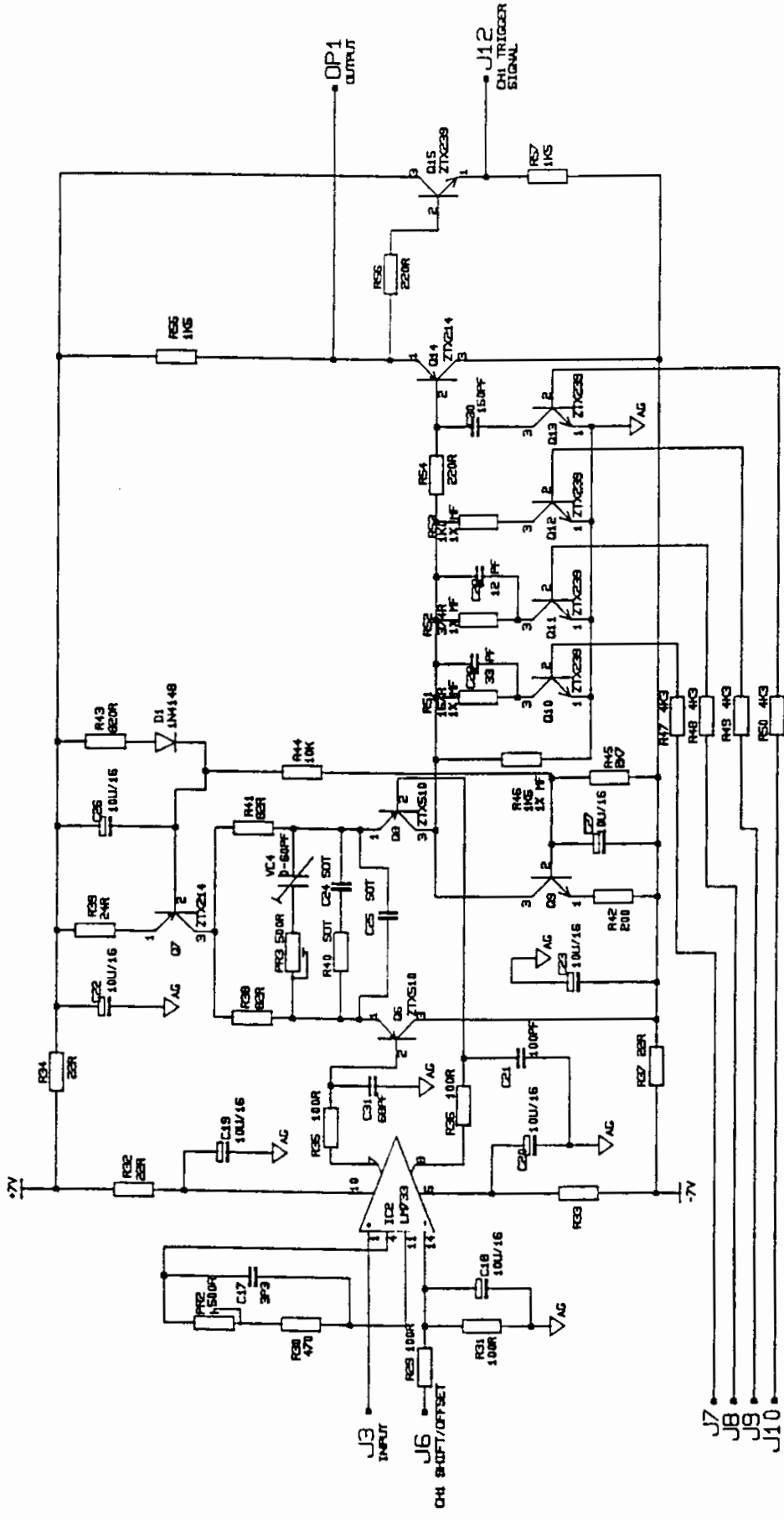

THURLBY ELECTRONICS LTD.	TITLE:	SH4. CH1 OUTPUT AMPLIFIER.	DRAWN	MR	DATE	XX.6.87.
			DRAWING NO			
ISSUE: 2.10.87. CHANGED C21, C24, R36, R52, R47-50						

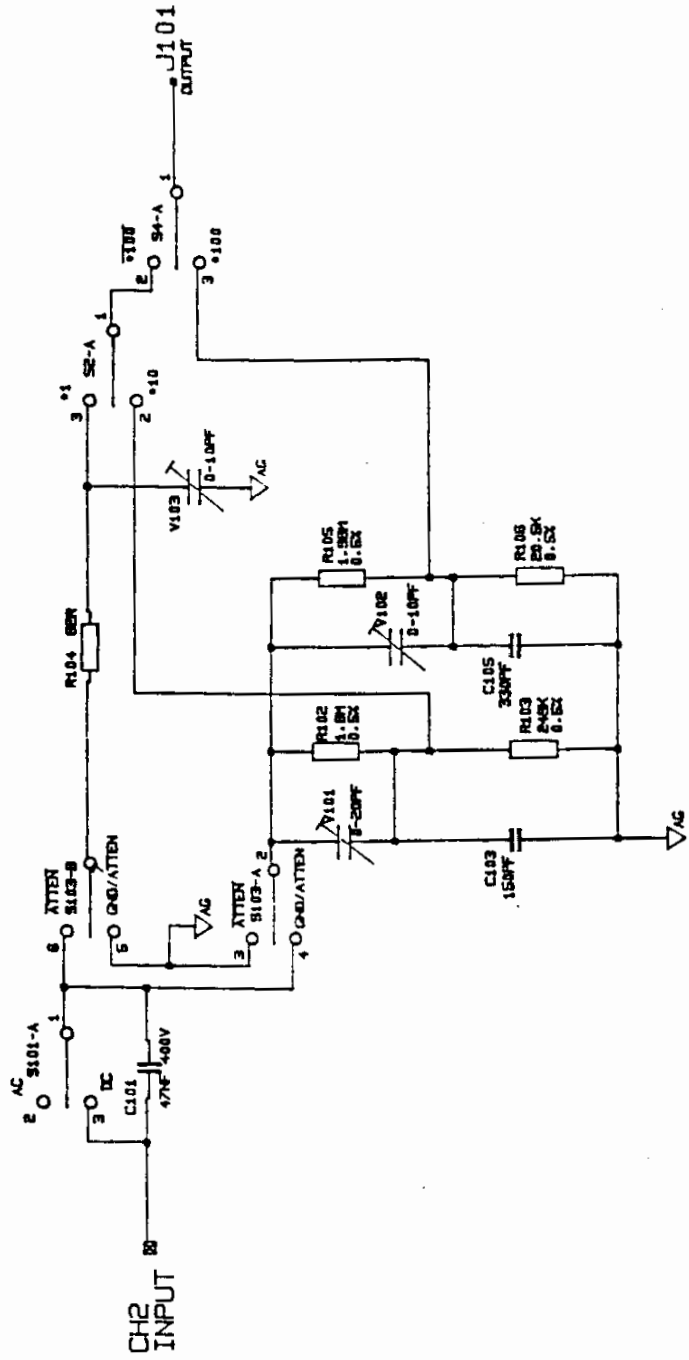

THURLBY ELECTRONICS LTD.  
 TITLE: SH5  
 CH2 INPUT ATTENUATOR

DRAWN MR  
 DRAWING NO

DATE 5.6.87.

TABLE 2. 1.10.87. IMPROVED 0.100 ATTEN.

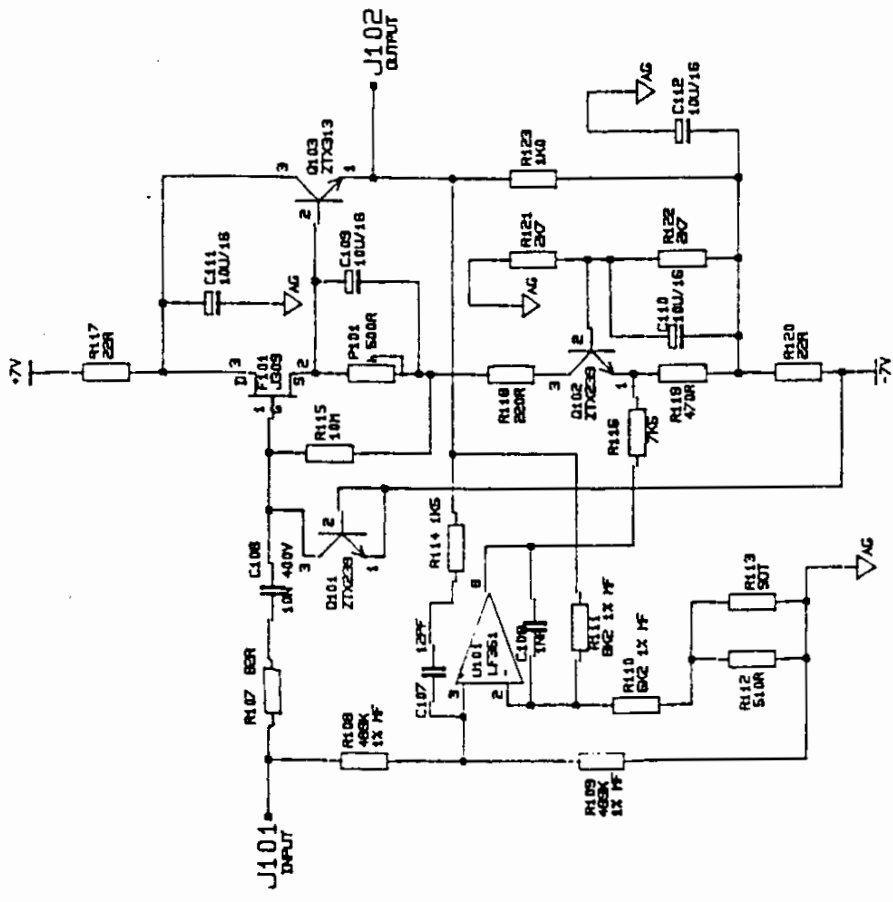

THURLBY ELECTRONICS LTD.  
 ISSUE B. 2-10-87. DWG NO. R107.108.109.120.C106.F101

TITLE: SH6. CH2  
 \* 1 HI-Z BUFFER.

DRAWN MR  
 DRAWING NO

DATE XX.6.87.

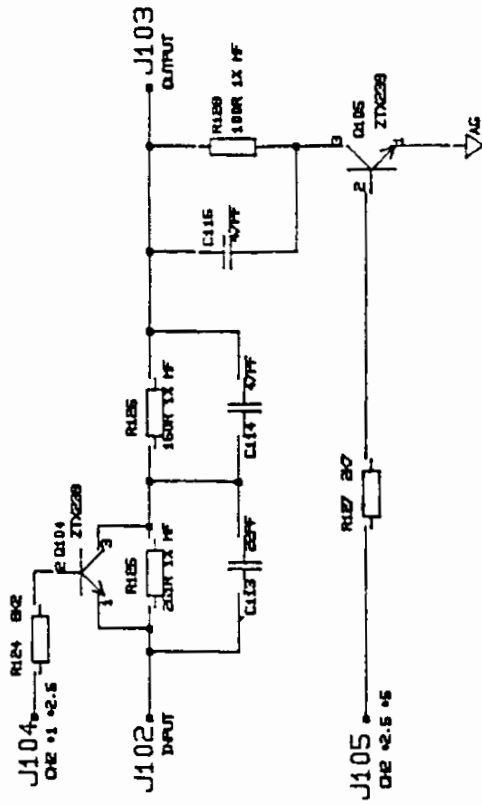

THURLBY ELECTRONICS LTD.

TITLE: CH2 \*1 \*2.5 \*5  
ATTENUATOR

DRAWN MR

DATE XX.6.87.

DRAWING NO

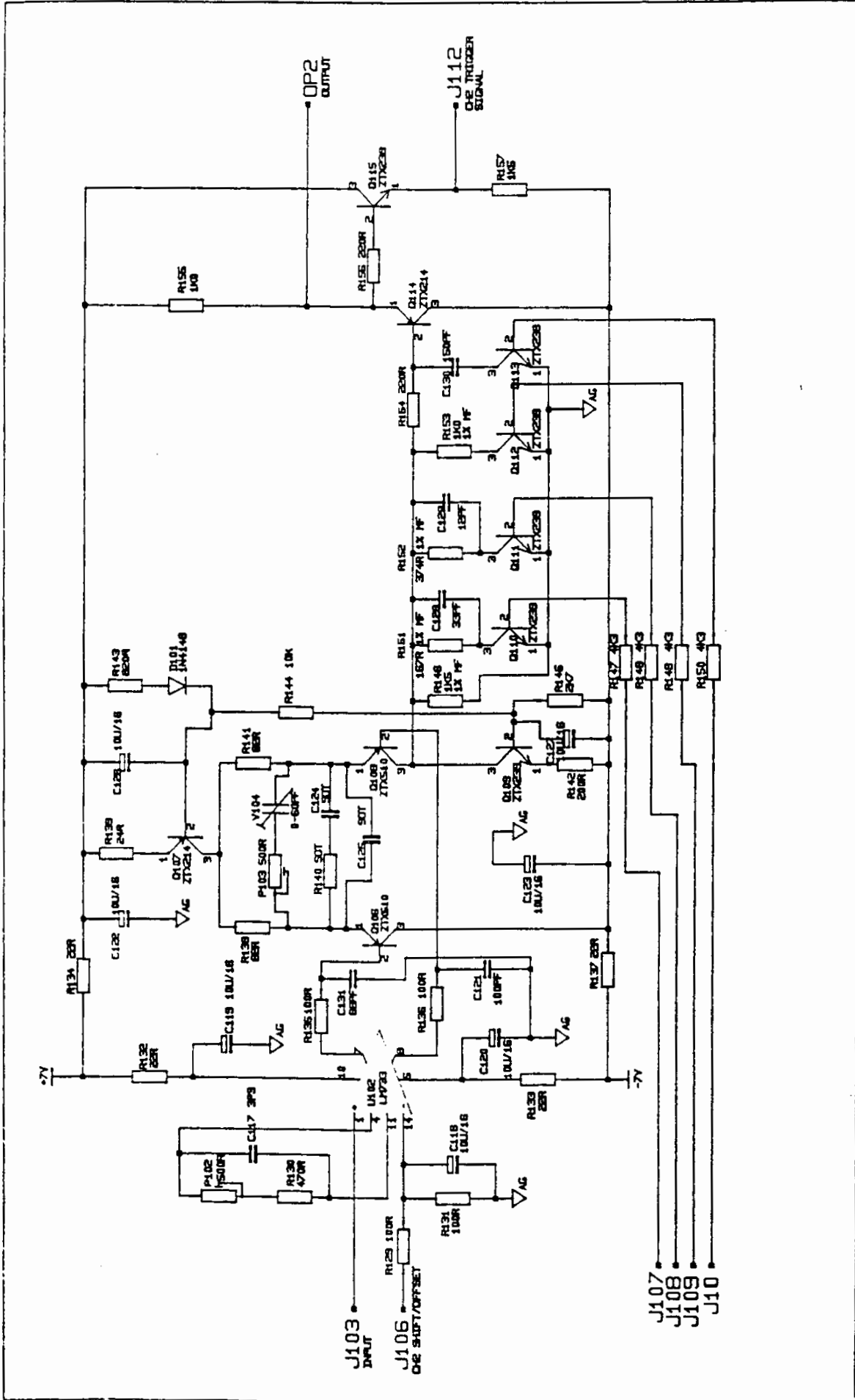

THURLBY ELECTRONICS LTD.	TITLE:	SHB. CH2 OUTPUT AMPLIFIER.	DRAWN	MR	DATE
			DRAWING NO		
<small>TABLE 2. 2-10-67. CHANGED R136, R147-150, R152, R155, R156, C121, C131</small>					

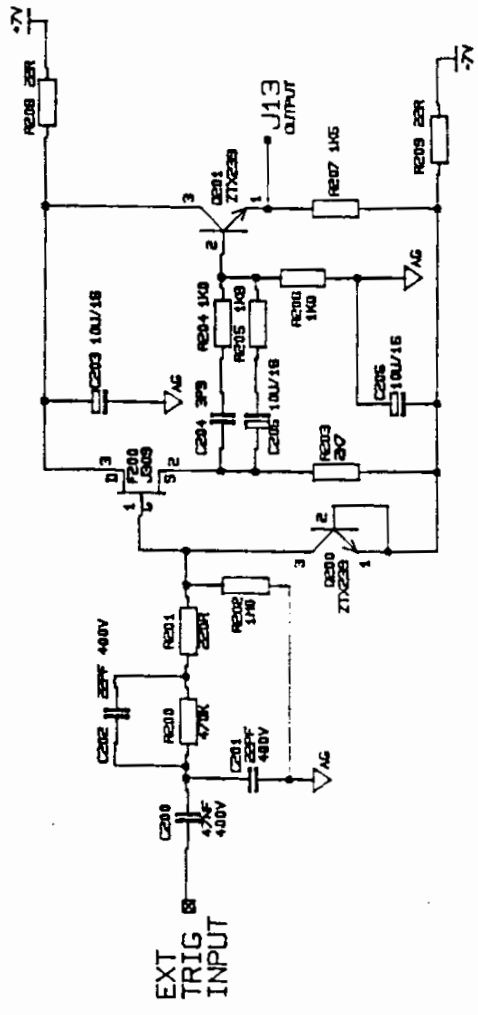

THURLBY ELECTRONICS LTD.

TITLE: SH9. EXT TRIGGER AMPLIFIER.

DRAWN MR DRAWING NO

DATE XX.6.87.

ISSUE 2. 2.10.87. DIMENSIONS C201, C202

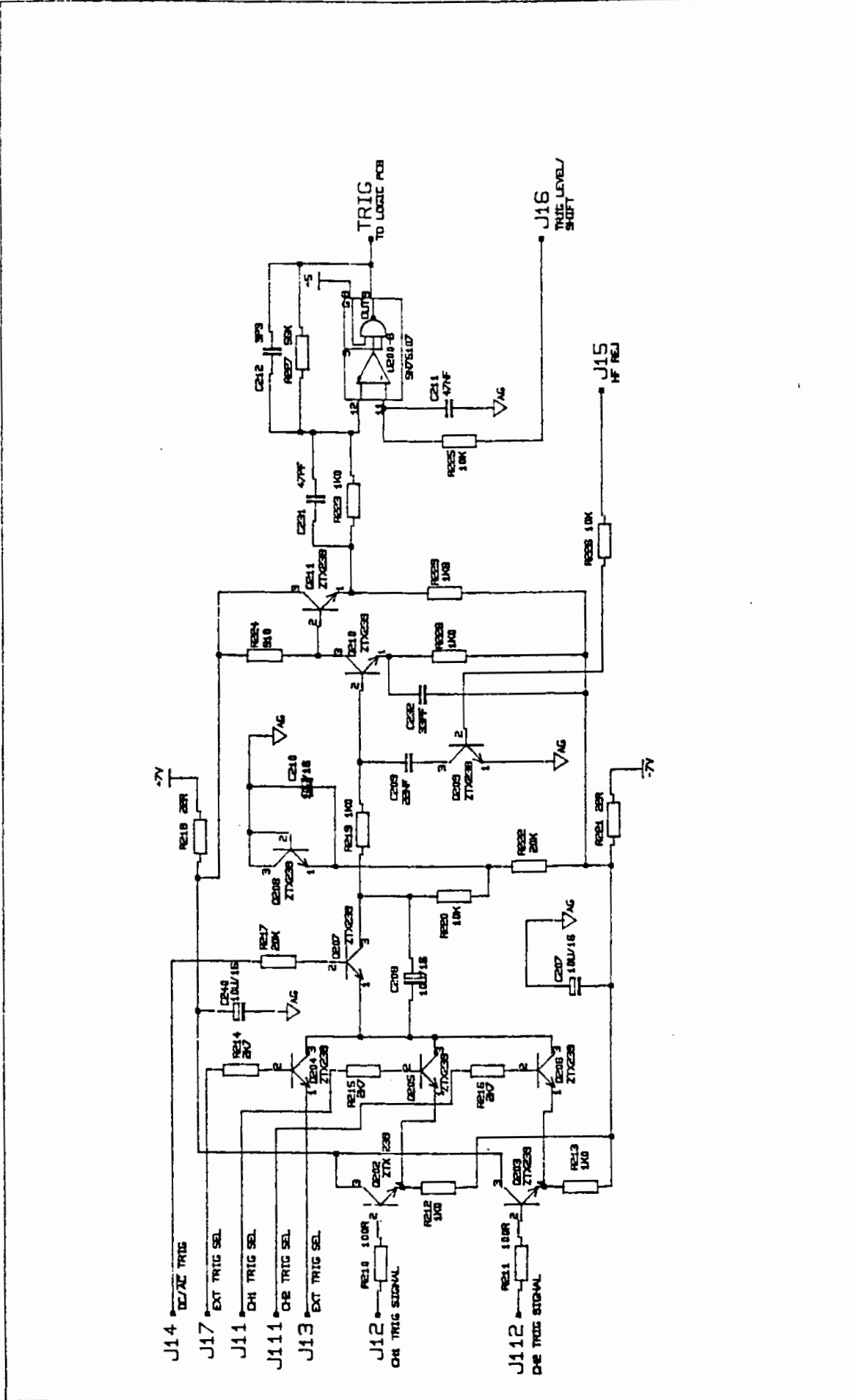

THURLBY ELECTRONICS LTD.	TITLE:	SH10. TRIGGER AMPLIFIER.	DRAWN MR	DATE XX.6.87.
ISSUE 2. 2.10.87. ADDED RES10, RES11, RES12, RES13. CHANGED CZ11			DRAWING No	



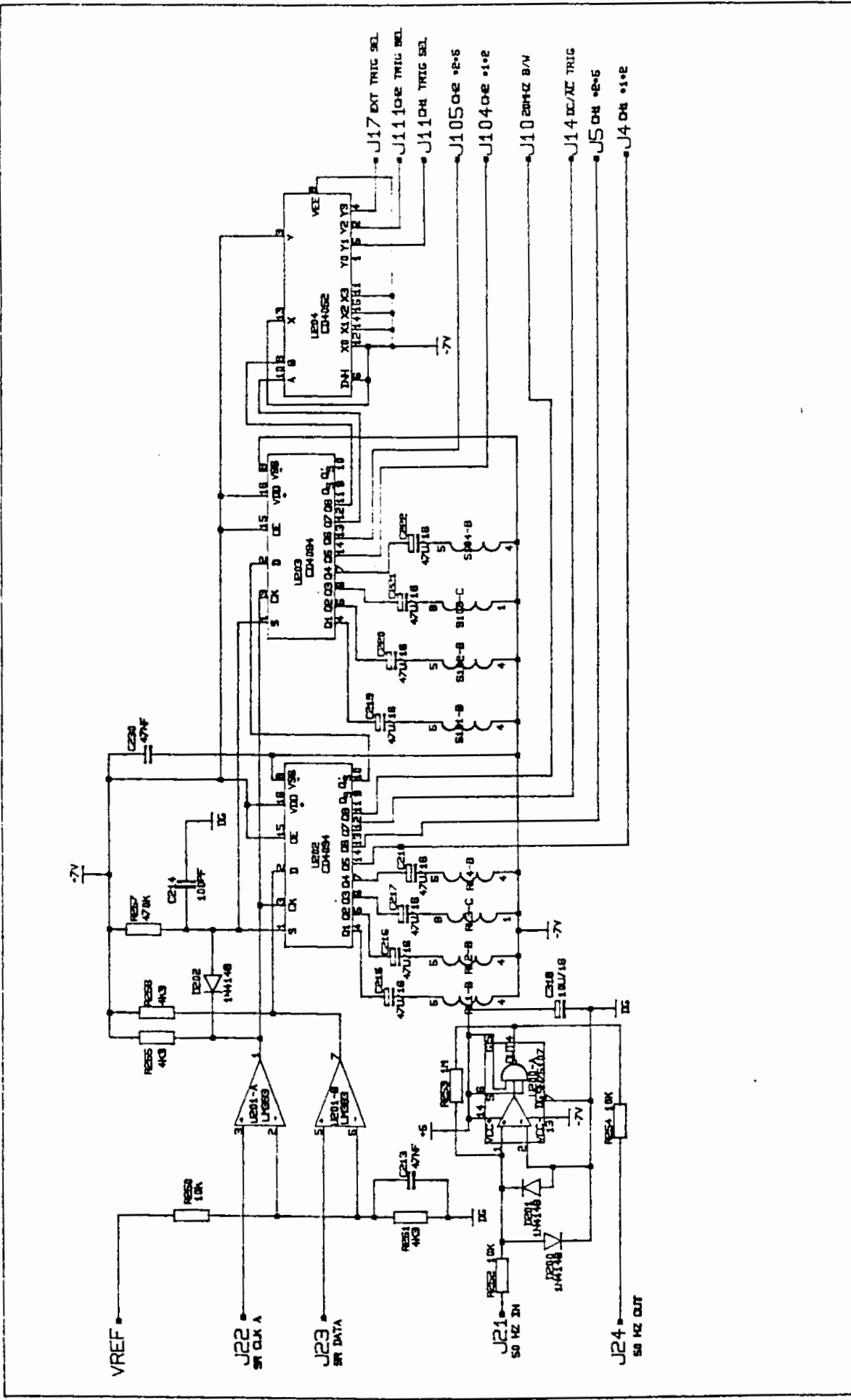

THURLBY ELECTRONICS LTD.	TITLE: SH11. DC CONTROL SIGNAL BLOCK.	DRAWN MR	DATE XX.6.87.
		DRAWING NO	
ISSUE 2. 2.10.87.			

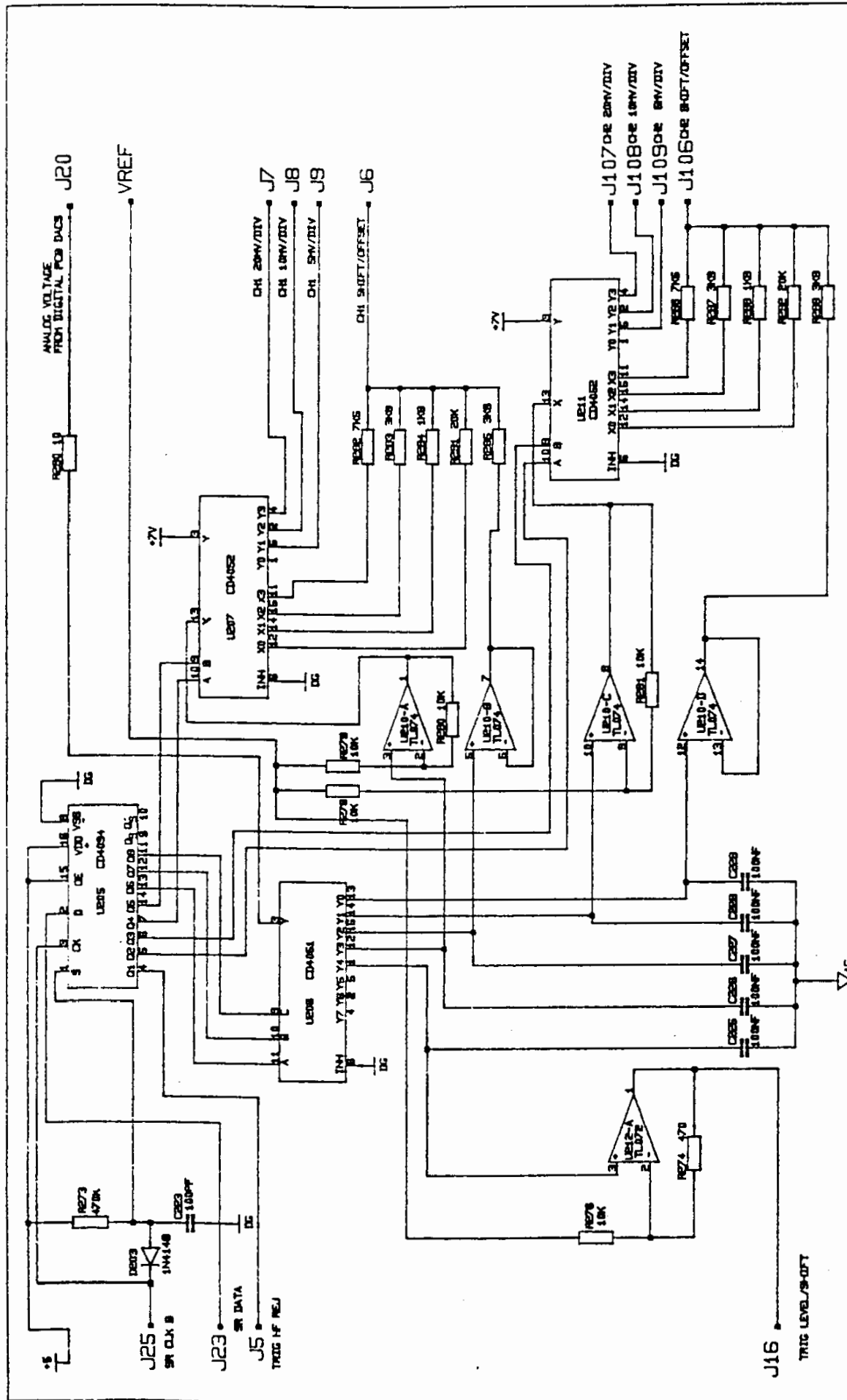

THURLBY ELECTRONICS LTD.	TITLE: SH12. SAMPLE/HOLD CIRCUITRY.	DRAWN MR DATE XX.6.87.
FILE 2. 2.10.87. CHANGED R274, R288.		DRAWING NO

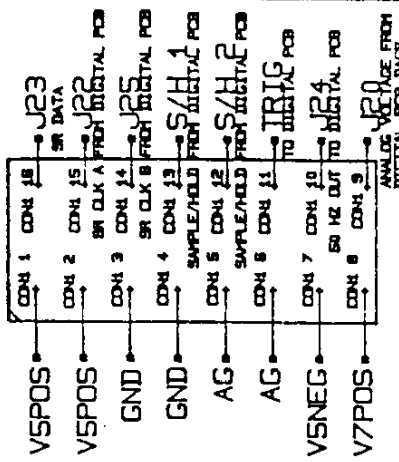
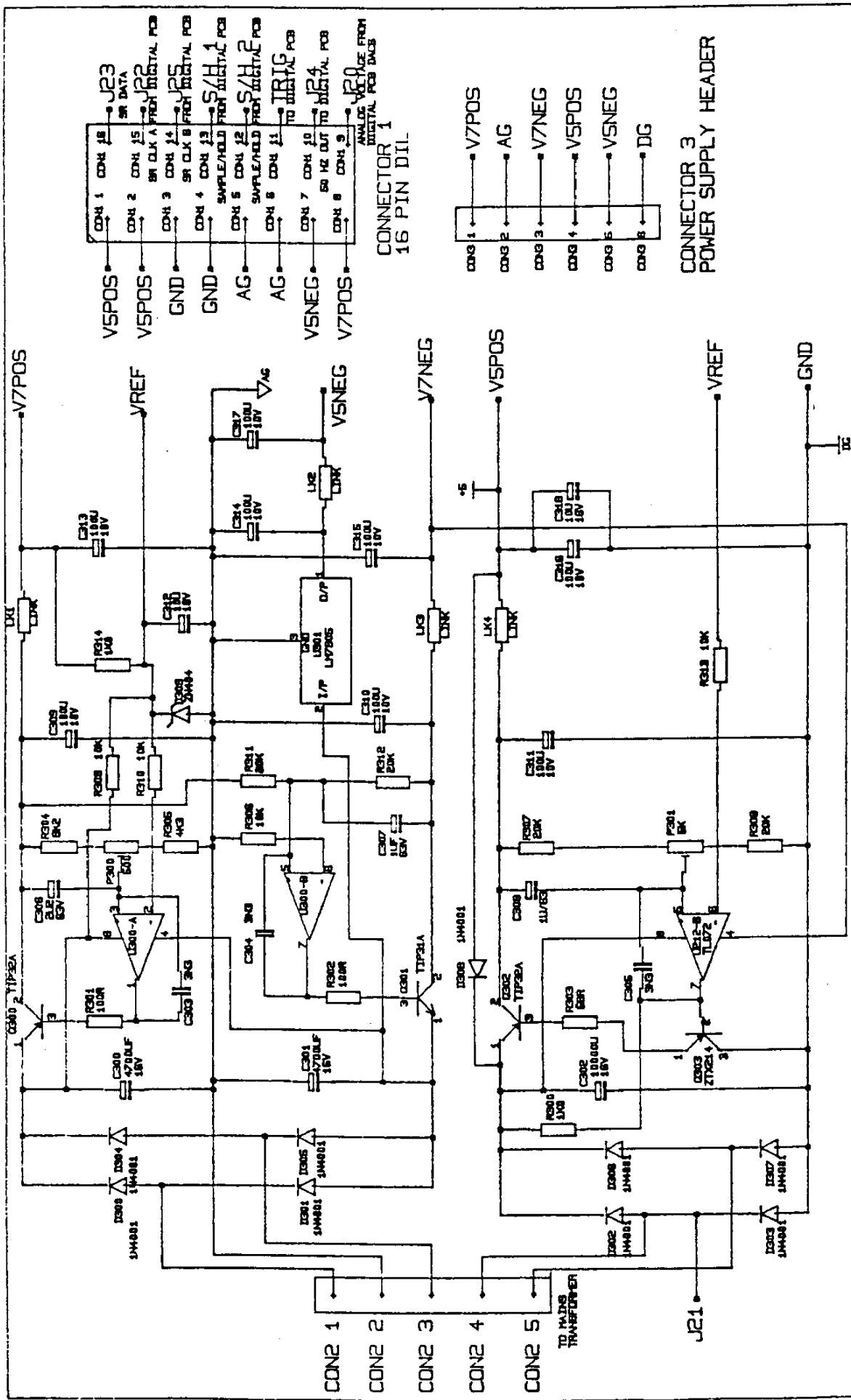

CONNECTOR 1  
16 PIN DIL

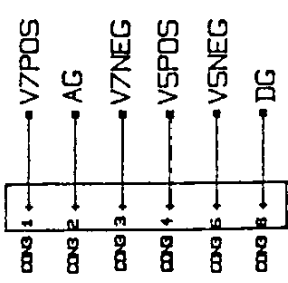

CONNECTOR 3  
POWER SUPPLY HEADER

THURLBY ELECTRONICS LTD.	TITLE:	SH13. DSA POWER SUPPLY.	DRAWN MR	DATE XX.6.87.
TO MAINS TRANSFORMER			DRAWING NO	
TABLE 2. 2.10.87. CHANGED LOGIC. P201.				

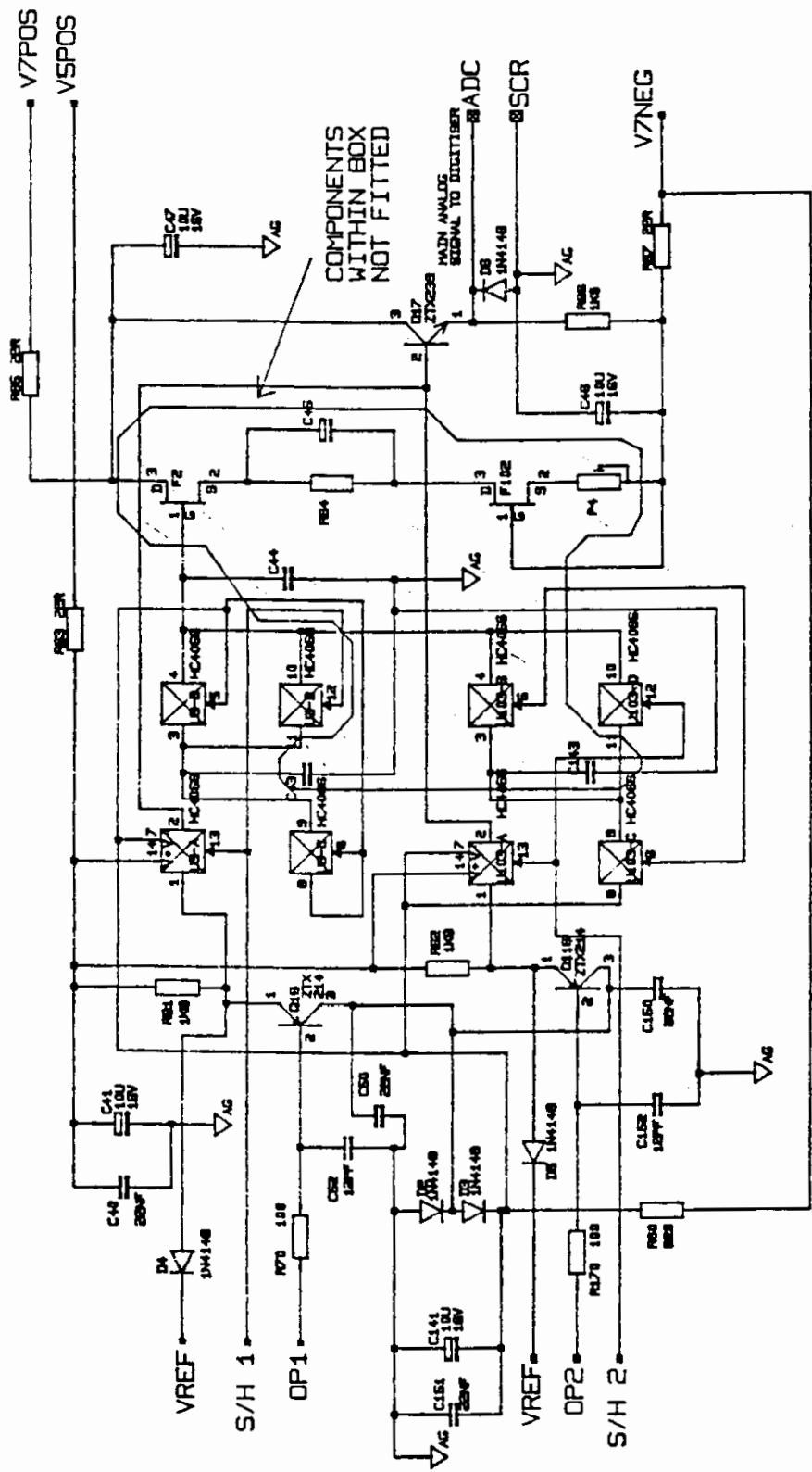

THURLBY ELECTRONICS LTD.	TITLE: SH14. SAMPLING CIRCUITS.	DRAWN MR	DATE 26.6.87
		DRAWING NO	
2. 2.10.87. P2. F102 ETC REMOVED.			

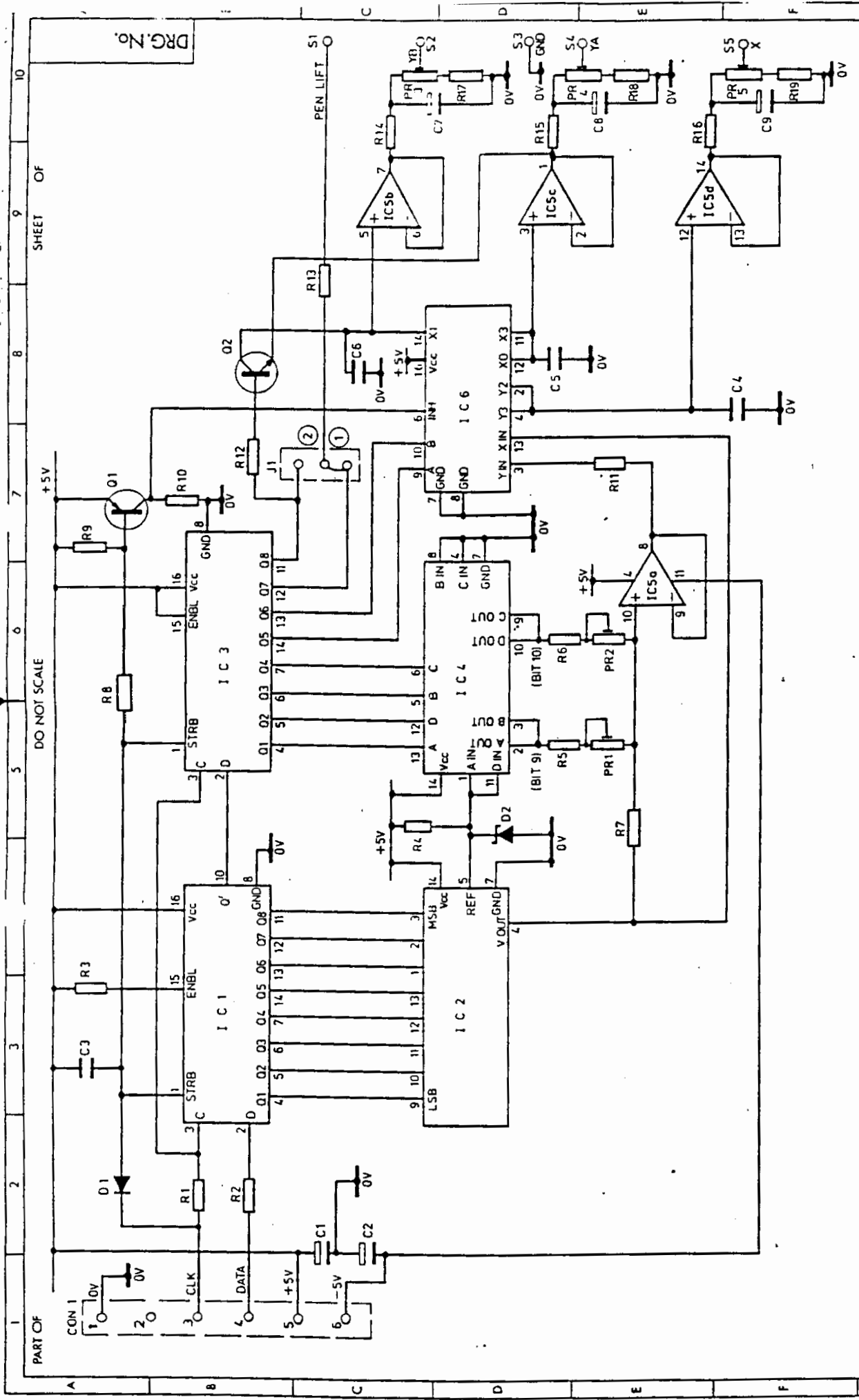

DRG. No.

SHEET OF

DO NOT SCALE

PART OF

ISSUE	DESCRIPTION	APPD DATE	TITLE	DRAWN	TRACED	CHECKED	APPROVED	DATE
1		1/7/77	THURLBY ELECTRONICS LTD. NEW ROAD, ST IVES, HUNTINGDON, CAMBS. PE17 4BG Tel. (0480) 63570	haz				1.7.87
			CIRCUIT DIAGRAM FOR APS11 ANALOG PLOTTER INTERFACE					
			DRAWING No.	c/10004				

DO NOT SCALE

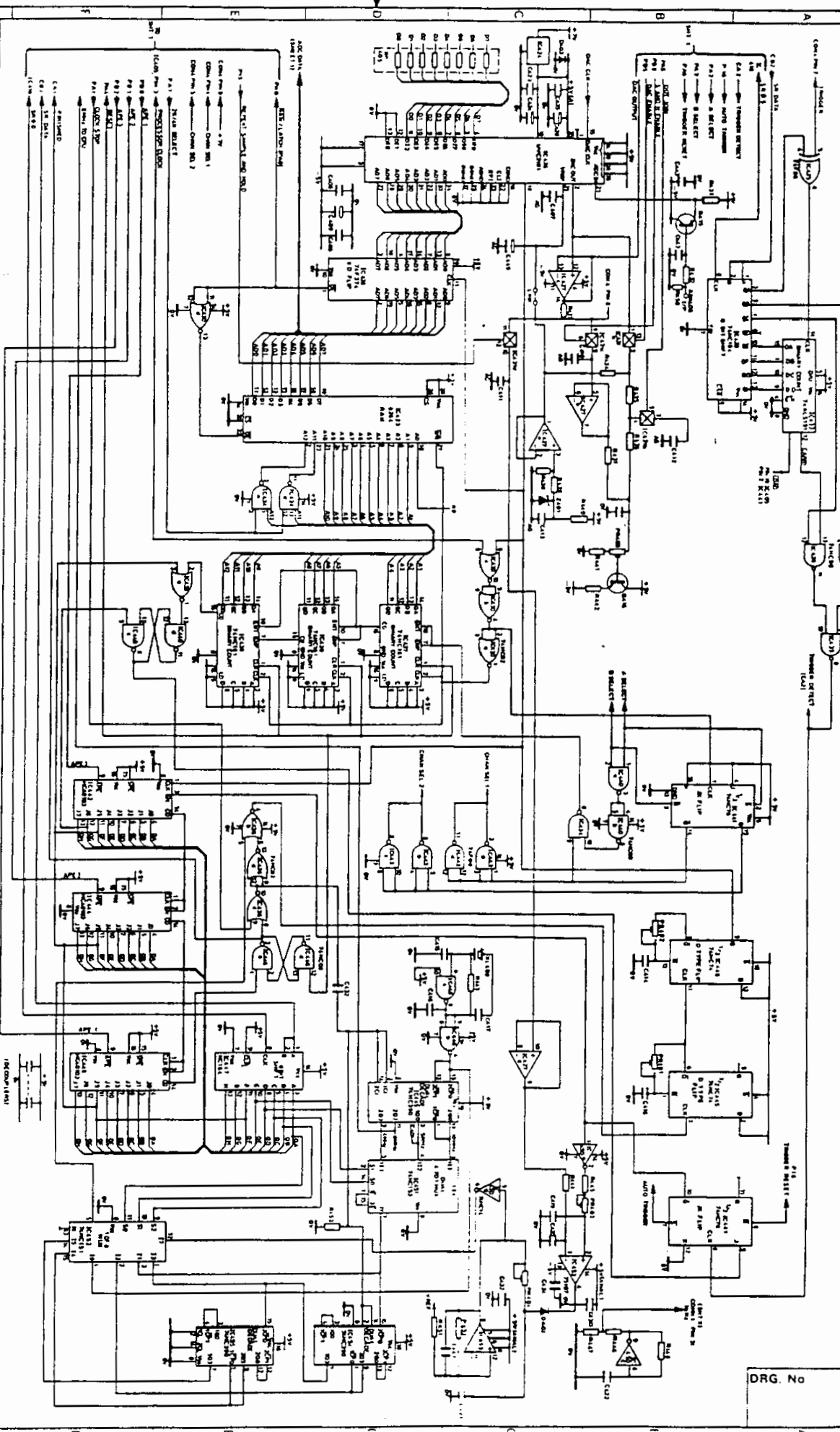

THURBY ELECTRONICS LTD.  
 NEW ROAD, ST IVES,  
 HUNTINGDON,  
 CAMBS PE11 4BG  
 TEL (0480) 63570

TITLE  
 CIRCUIT DIAGRAM FOR DSOA  
 PROCESSOR BOARD

DRAWING No  
 452

1	2	3	4	5	6	7	8	9	10
1	2	3	4	5	6	7	8	9	10

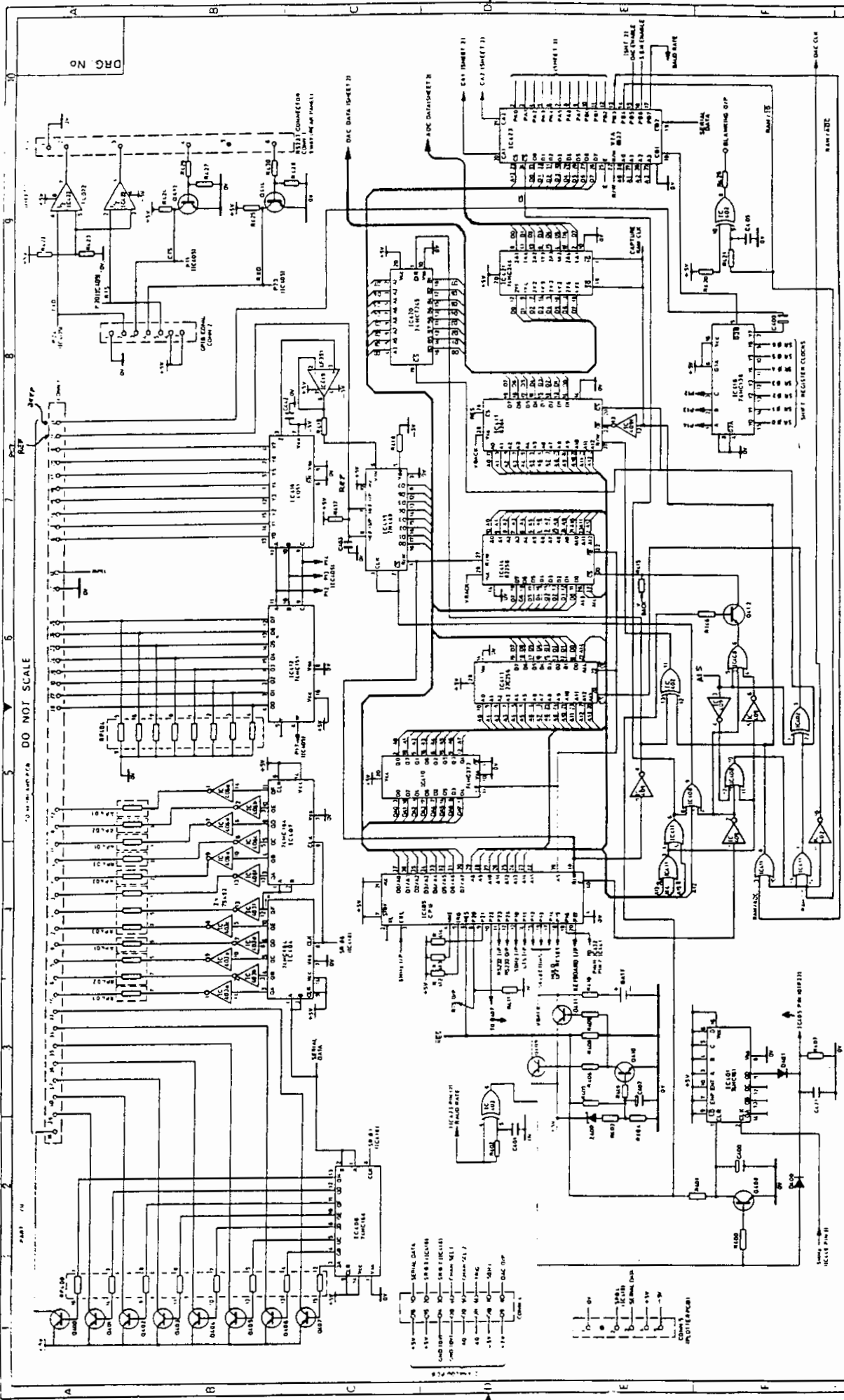

3	DESCRIPTION									
4	APPROVED									
5	DATE									
6	DRAWN									
7	CHECKED									
8	APPROVED									
9	DATE									
<p>TITLE: CIRCUIT DIAGRAM FOR DSOA PROCESSOR BOARD</p> <p>THURLBY ELECTRONICS LTD          NEW ROAD, ST IVES,          HUNTINGDON,          CAMBS. PE17 4BG          Tel (0480) 63570</p>										
DRAWING No.										
c/Tono. 24										
Sheet 1 of 2										

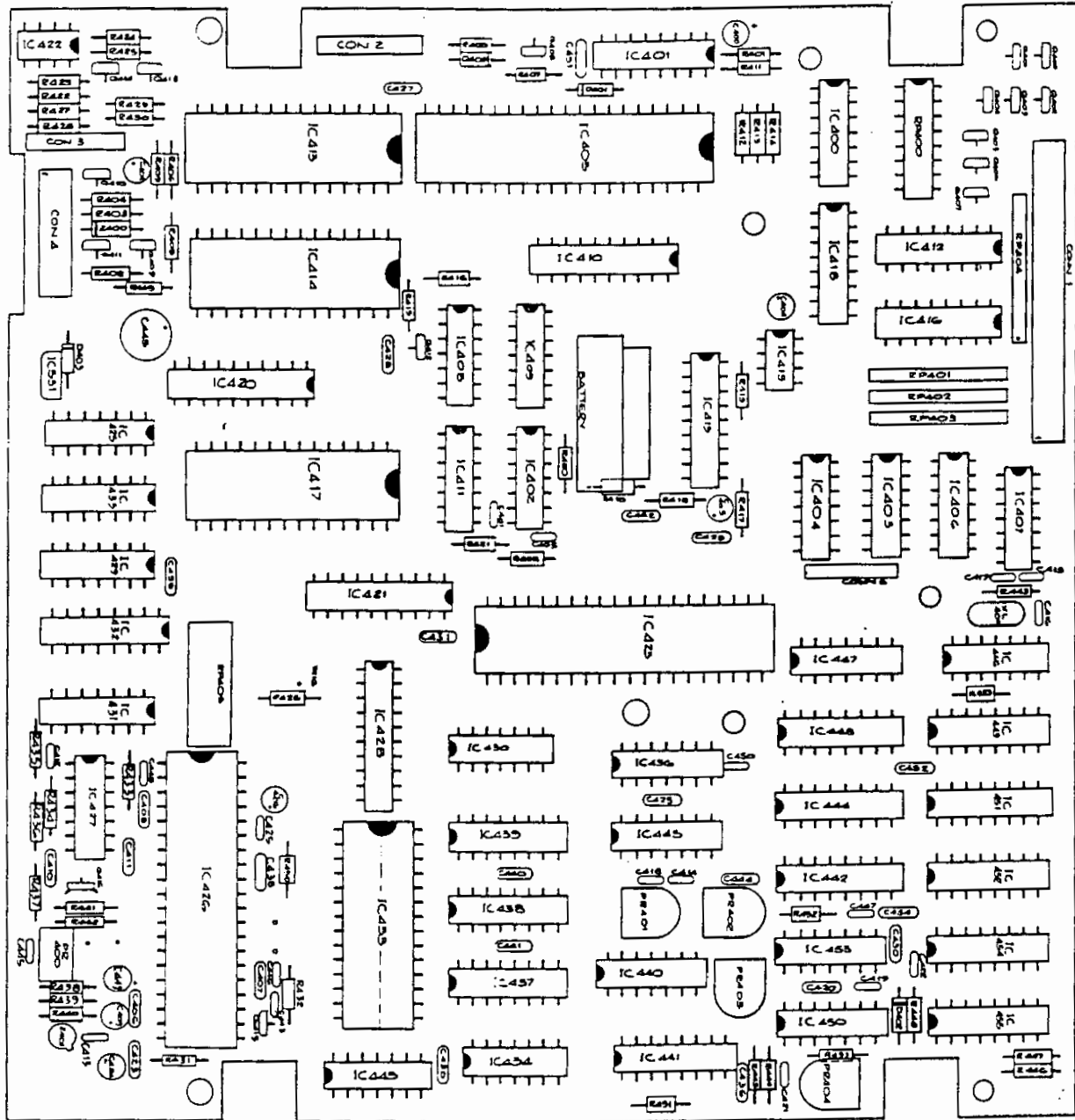

COMPONENT LAYOUT FOR DSOA PROCESSOR BOARD



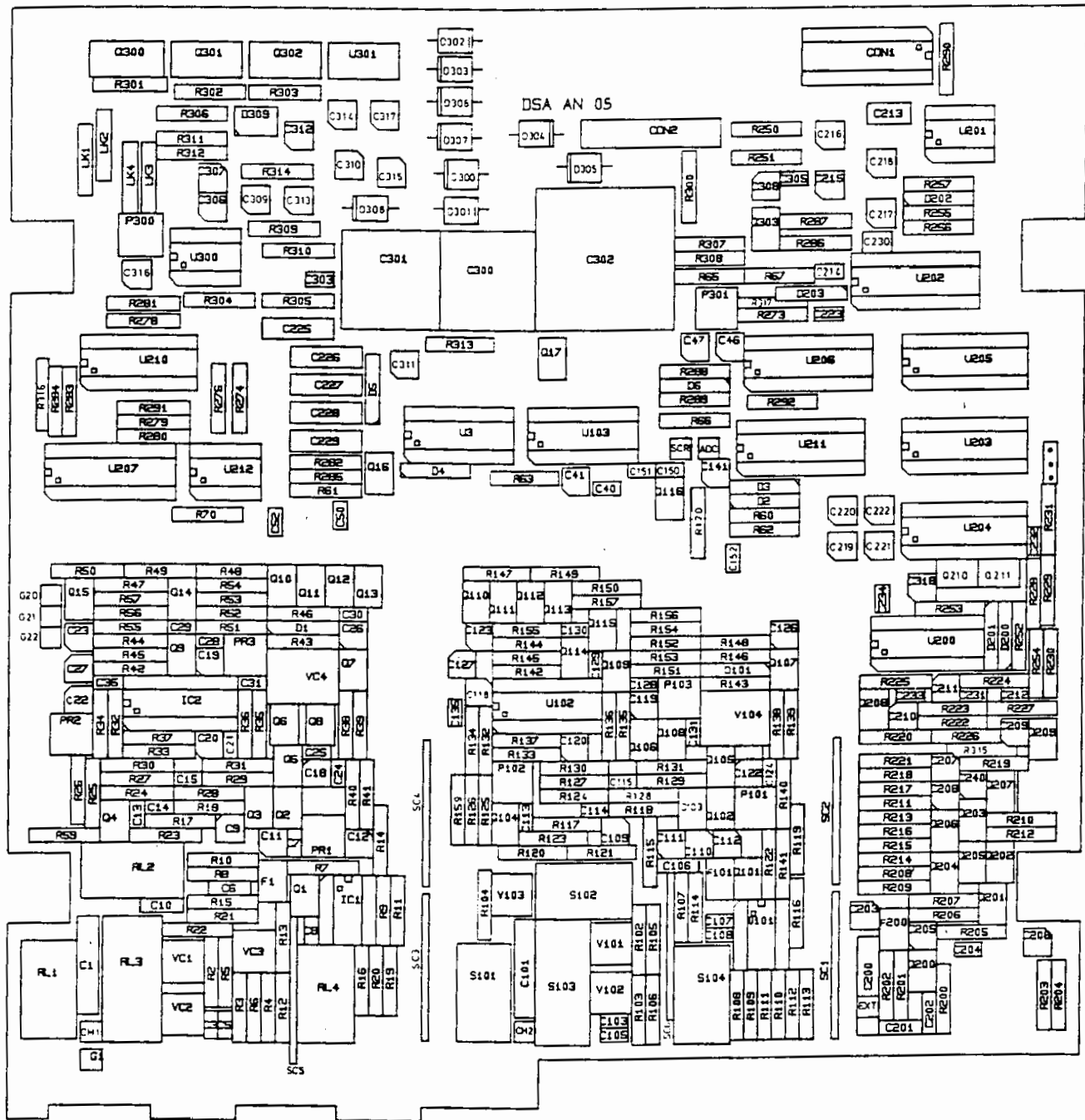

COMPONENT LAYOUT FOR ANALOGUE PCB

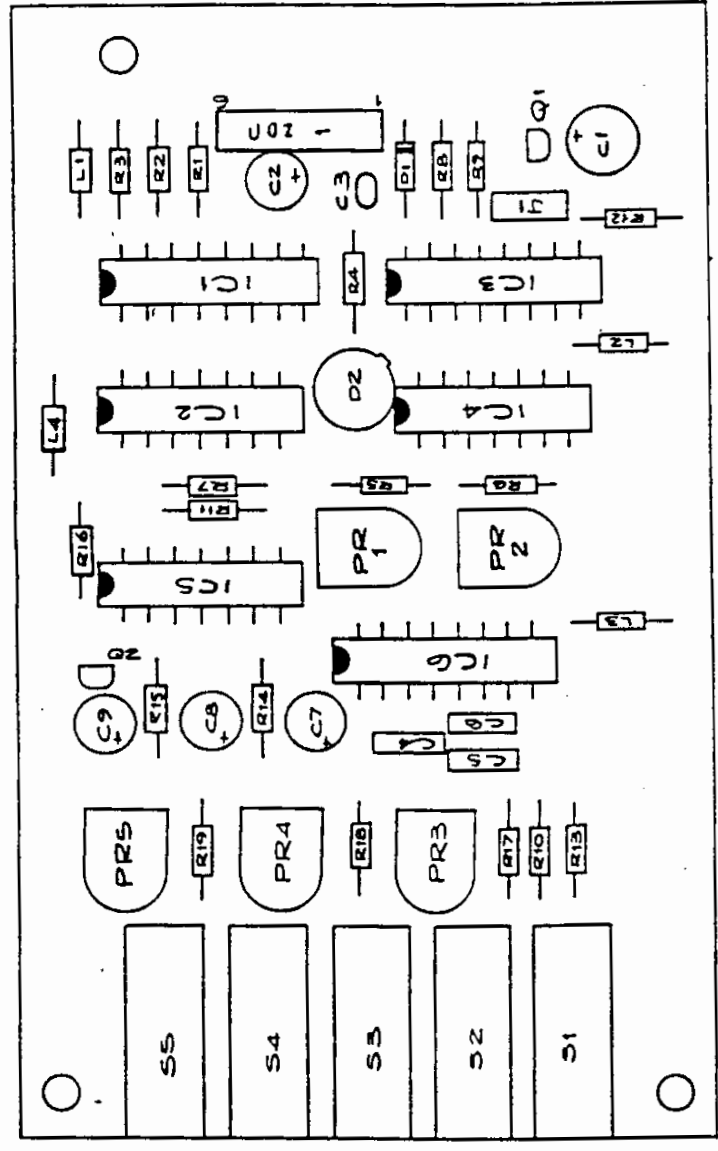

DRG. No.

SCALE 2:1

DESCRIPTION	APPD	DATE	TITLE	COMPONENT IDENT	DRAWN	TRACED	CHECKED	APPROVED	DATE
			THURLBY ELECTRONICS LTD, NEW ROAD, ST IVES, HUNTINGDON, CAMBS. PE17 4BG Tel. (0480) 63570	FOR APS11	<i>hual</i>				2.7.87
		4/79							
		8/79							
1									
2									
3									
4									
5									
6									
7									
8									
9									
10									
DRAWING No. CL100025									

## DIGITAL PCB ASSEMBLY

PART NUMBER	DESCRIPTION	QTY	CIRCUIT REFERENCE
22010-101	2.4V PCB Mounting Battery	1	
23180-107	560R 1/3W 5% CF Resistor	2	R417,R452
23180-113	2K7 1/3W 5% CF Resistor	4	R406,R408,R409,R434
23180-124	680R 1/3W 5% CF Resistor	1	R410
23180-127	39K 1/3W 5% CF Resistor	1	R438
23180-129	10M 1/3W 5% CF Resistor	1	R443
23180-131	470R 1/3W 5% CF Resistor	3	R444,R445,R453
23180-139	220R 1/3W 5% CF Resistor	1	R431
23180-148	1K 1/3W 5% CF Resistor	2	R440,R442
23180-153	47R 1/3W 5% CF Resistor	1	R403
23180-158	100K 1/3W 5% CF Resistor	1	R448
23180-161	390R 1/3W 5% CF Resistor	1	R453
23180-163	10K 1/3W 5% CF Resistor	12	R400,R401,R402,R411,R412 R413,R414,R415,R416,R420 R421,R439
23180-172	120R 1/3W 5% CF Resistor	1	R404
23180-186	4K3 1/3W 5% CF Resistor	2	R418,R419
23180-187	13K 1/3W 5% CF Resistor	1	R441
23180-194	4K7 1/3W 5% CF Resistor	10	R405,R407,R422,R423,R424 R425,R427,R428,R429,R430
23180-204	100R 1/3W 5% CF Resistor	3	R432,R433,R450
23180-205	270R 1/3W 5% CF Resistor	2	R426,R449
23203-318	1K 1% 50ppm MF Resistor	1	R447
23203-359	3K0 1% 50ppm MF Resistor	1	R437
23203-361	1K5 1% 50ppm MF Resistor	3	R435,R436,R451
23203-389	4K02 1% 50ppm MF Resistor	1	R446
23301-102	10K x 8 SIL Resistor Pack	1	RP404
23301-103	47R x 4 SIL Resistor Pack	3	RP401,402,403
23330-002	2K2 x 8 CF DIL Res. Pack	2	RP400,RP405
23376-002	1K 10mm Hor. CF Preset	2	PR401,PR402
23376-006	500R 10mm Hor. CF Preset	2	PR403,PR404
23376-205	2K2 10mm Ver. CF Preset	1	PR400
23424-401	47nF Ceramic Disc Cap.	20	C406,C407,C408,C420,C423 C425,C427,C428,C429,C430 C431,C432,C424,C436,C438 C439,C440,C441,C442,C444
23427-209	33p Ceramic Plate Cap.	2	C416,C421
23427-215	10n Ceramic Plate Cap.	4	C413,C422,C425,C443
23427-218	330p Ceramic Plate Cap.	5	C401,C412,C419,C448,C450
23427-219	22p Ceramic Plate Cap.	1	C446
23427-220	68p Ceramic Plate Cap.	1	C447
23427-221	12p Ceramic Plate Cap.	5	C414,C415,C417,C418,C445
23427-233	150p Ceramic Plate Cap.	1	C451
23427-246	1n2 Ceramic Plate Cap.	1	C405
23557-103	1uF 63V Radial Elec. Cap.	1	C402
23557-107	22uF 16V Radial Elec. Cap	7	C400,C403,C404,C409,C424 C426,C449

PART NUMBER	DESCRIPTION	QTY	CIRCUIT REFERENCE
23557-115	470uF 10V Radial Elec.Cap	1	C445
23620-007	10nF Polyester Capacitor	2	C410,C411
25021-001	1N4148 Diode	4	D400,D401,D402,D403
25130-203	3V9 Zener Diode	1	Z400
25341-200	ZTX214 Transistor	10	Q400,Q401,Q402,Q403,Q404 Q405,Q406,Q407,Q409,Q411
25380-251	ZTX239 Transistor	6	Q408,Q410,Q412,Q413,Q414 Q416
25381-304	ZTX510 Transistor	1	Q415
27106-501	LF351N Int. Circuit	1	IC419
27106-507	TL074 Int. Circuit	1	IC427
27106-508	TL072 Int. Circuit	1	IC422
27153-103	UVC3120-8 Int. Circuit	1	IC426
27153-704	ZN449E Int. Circuit	1	IC415
27156-010	CD4051 Int. Circuit	1	IC416
27156-016	74HC4066 Int. Circuit	1	IC431
27160-016	78L005 Int. Circuit	1	IC531
27161-801	ZN404 Int. Circuit	1	Z401
27202-005	74HC4075 Int. Circuit	1	IC408
27203-022	74HC00N Int. Circuit	5	IC434,IC435,IC440,IC443 IC446
27204-012	74HC02 Integrated Circuit	2	IC430,IC436
27204-013	74HC32 Integrated Circuit	1	IC411
27205-004	74F86 Integrated Circuit	1	IC425
27205-010	74HC86 Integrated Circuit	1	IC402
27210-006	74HCT245 Int. Circuit	1	IC420
27211-102	DS75107 Int. Circuit	1	IC453
27212-009	74HC14 Int. Circuit	2	IC409,IC450
27214-009	74HC244 Int. Circuit	1	IC421
27232-015	74AC374 Int. Circuit	1	IC428
27232-021	74HC373 Int. Circuit	1	IC410
27232-024	74HC74 Int. Circuit	1	IC445
27233-001	74HC76 Integrated Circuit	1	IC441
27240-403	HD6303RP Int. Circuit	1	IC405
27240-803	DS75492 Int. Circuit	2	IC403,IC406
27240-804	65C22 Integrated Circuit	1	IC423
27241-011	6264(150ns) Int. Circuit	1	IC417
27241-203	32K x 8 CMOS SRAM (LP)	1	IC433
27241-204	8K x 8 High Speed SRAM	1	IC414
	27C256 Int. Circuit	1	IC413 (Programmed)
27252-017	74HC161 Int. Circuit	4	IC401,IC437,IC438,IC439
27252-018	74ALS191 Int. Circuit	1	IC432
27252-020	74HC40103 Int. Circuit	3	IC442,IC444,IC448
27252-023	74HC390 Int. Circuit	3	IC449,IC454,IC455
27253-006	74HC153 Int. Circuit	1	IC451
27255-009	74HC151 Int. Circuit	2	IC412,IC452
27255-010	74HC138 Int. Circuit	1	IC418
27266-016	74HC164 Int. Circuit	5	IC400,IC404,IC407,IC429 IC447
28500-002	20MHz Crystal	1	XL400

ANALOGUE PCB ASSEMBLY

PART NUMBER	DESCRIPTION	QTY	CIRCUIT REFERENCE
22247-604	Mini Relay 1p C/O	6	RL1,RL2,RL4,S101,S102 S104
22247-605	Mini Relay 2p C/O	2	RL3,S103
23180-101	3K9 1/3W 5% CF Resistor	2	R283,R287
23180-108	15k 1/3W 5% CF Resistor	2	R316,R317
23180-111	82R 1/3W 5% CF Resistor	6	R7,R38,R41,R107,R138 R141
23180-113	2k7 1/3W 5% CF Resistor	14	R21,R22,R27,R45,R121,R122 R127,R145,R203,R214,R215 R216,R229,R315
23180-118	510R 1/3W 5% CF Resistor	2	R12,R112
23180-124	680R 1/3W 5% CF Resistor	2	R61,R62
23180-126	20K 1/3W 5% CF Resistor	6	R217,R273,R291,R292 R305,R307
23180-127	39K 1/3W 5% CF Resistor	1	R304
23180-129	10M 1/3W 5% CF Resistor	2	R15,R115
23180-130	33R 1/3W 5% CF Resistor	4	R4,R104,R225,R303
23180-131	470R 1/3W 5% CF Resistor	4	R19,R66,R119,R274
23180-133	7K5 1/3W 5% CF Resistor	4	R16,R116,R284,R288
23180-137	1M 1/3W 5% CF Resistor	2	R202,R257
23180-139	220R 1/3W 5% CF Resistor	12	R18,R35,R36,R54,R56,R60 R118,R135,R136,R154,R156 R201
23180-140	820R 1/3W 5% CF Resistor	2	R43,R143
23180-141	1K8 1/3W 5% CF Resistor	5	R205,R282,R285,R286,R289
23180-148	1K 1/3W 5% CF Resistor	14	R23,R55,R57,R123,R155,R157 R204,R212,R213,R219,R223 R228,R300,R314
23180-158	100K 1/3W 5% CF Resistor	2	R200,R253
23180-160	22R 1/3W 5% CF Resistor	20	R17,R20,R32,R33,R34,R37,R63 R65,R67,R117,R120,R132,R133 R134,R137,R208,R209,R218 R221,R290
23180-161	390R 1/3W 5% CF Resistor	2	R30,R130
23180-163	10K 1/3W 5% CF Resistor	16	R44,R144,R206,R220,R222,R226 R250,R252,R254,R276,R278,R279 R306,R309,R310,R313
23180-167	910R 1/3W 5% CF Resistor	1	R224
23180-170	56K 1/3W 5% CF Resistor	1	R227
23180-174	1K5 1/3W 5% CF Resistor	3	R14,R114,R207
23180-186	4K3 1/3W 5% CF Resistor	11	R47,R48,R49,R50,R147,R148 R149,R150,R251,R255,R256
23180-201	18K 1/3W 5% CF Resistor	1	R308
23180-204	100R 1/3W 5% CF Resistor	14	R29,R31,R40,R70,R129,R131 R140,R170,R210,R211,R230 R231,R301,R302

PART NUMBER	DESCRIPTION	QTY	CIRCUIT REFERENCE
23180-212	9K1 1/3W 5% CF Resistor	2	R280,R281
23180-218	24R 1/3W 5% CF Resistor	2	R39,R139
23180-219	160R 1/3W 5% CF Resistor	2	R42,R142
23203-318	1K 1% 50ppm MF Resistor	2	R53,R153
23203-368	100R 1% 50ppm MF Resistor	2	R28,R128
23203-384	374R 1% 50ppm MF Resistor	2	R52,R152
23203-390	6K2 1% 50ppm MF Resistor	8	R10,R11,R24,R110,R111,R124 R311,R312
23203-393	499K 1% 50ppm MF Resistor	4	R8,R9,R108,R109
23203-395	167R 1% 50ppm MF Resistor	2	R51,R151
23203-398	270R 1% 50ppm MF Resistor	2	R26,R126
23203-399	360R 1% 50ppm MF Resistor	4	R25,R59,R125,R159
23203-400	1k6 1% 50ppm MF Resistor	2	R46,R146
23221-209	1M8 0.5% 50ppm MF Res.	2	R2,R102
23221-210	1M98 0.5% 50ppm MF Res.	2	R5,R105
23221-211	249K 0.5% 50ppm MF Res.	2	R3,R103
23221-213	20k5 0.5% 50ppm MF Res.	2	R6,R106
23376-603	500R 6mm Hor Cerm. Preset	6	PR1,PR2,PR3,P101,P102,P103
23376-604	5k 6mm Hor Cerm. Preset	2	P300,P301
23424-401	47nF Ceramic Disc Cap.	2	C10,C213
23424-406	10nF 500V. Cer. Disc Cap.	2	C6,C106
23424-420	22pF 400V. Cer. Disc Cap.	2	C201,C202
23427-200	100pF Ceramic Plate Cap.	1	C214
23427-203	1n Ceramic Plate Cap.	2	C8,C108
23427-205	47p Ceramic Plate Cap.	9	C13,C14,C24,C35,C113,C114,C124 C131,C135
23427-207	22n Ceramic Plate Cap.	7	C40,C50,C150,C151,C209,C230 C234
23427-209	33pF Ceramic Plate Cap.	1	C29
23427-210	3p3 Ceramic Plate Cap.	2	C204,C212
23427-213	5p6 Ceramic Plate Cap.	2	C21,C31
23427-214	82p Ceramic Plate Cap.	2	C28,C128
23427-217	3n3 Ceramic Plate Cap.	2	C303,C305
23427-219	22p Ceramic Plate Cap.	3	C25,C129,C232
23427-220	68p Ceramic Plate Cap.	2	C30,C130
23427-221	12p Ceramic Plate Cap.	5	C7,C52,C107,C152,C233
23427-233	150p Ceramic Plate Cap.	5	C15,C103,C115,C223,C231
23427-247	330pF Ceramic Cap. Low K	2	C5,C105
23427-248	180pF Ceramic Plate Cap.	1	C3
23557-100	100uF 10V Radial Elec.Cap	8	C309,C310,C311,C313,C314 C315,C316,C317
23557-104	47uF 16V Radial Elec. Cap	8	C215,C216,C217,C218,C219,C220 C221,C222

PART NUMBER	DESCRIPTION	QTY	CIRCUIT REFERENCE
23557-114	10uF 16V Radial Elec. Cap	35	C9,C11,C12,C18,C19,C20,C22 C23,C26,C27,C41,C46,C47,C109 C110,C111,C112,C118,C119,C120 C122,C123,C126,C127,C141,C203 C205,C206,C207,C208,C210,C211 C240,C312,C318
23557-116	2u2 63V Radial Elec. Cap.	3	C306,C307,C308
23557-117	10000uF 16V Radial Elec.	1	C302
23557-122	4700uF 16V Elec. Cap	2	C300,C301
23620-001	0.1uF 100V 10% Polyester	5	C225,C226,C227,C228,C229
23620-008	0.047uF 400V. Polyester	3	C1,C101,C200
23984-001	2 - 10pF Plastic Trimmer	4	VC2,VC3,V102,V103
23984-002	5 - 60pF Plastic Trimmer	2	VC4,V104
23984-004	2 - 20pF Plastic Trimmer	2	VC1,V101
25021-001	1N4148 Diode	11	D1,D2,D3,D4,D5,D6,D101,D200 D201,D202,D203
25115-001	1N4003 Diode	9	D300,D301,D302,D303,D304 D305,D306,D307,D308
25341-200	ZTX214 Transistor	5	Q7,Q14,Q107,Q114,Q303
25380-251	ZTX239 Transistor	33	Q1,Q2,Q4,Q5,Q9,Q10,Q11,Q12 Q13,Q15,Q17,Q101,Q102,Q104 Q105,Q109,Q110,Q111,Q112 Q113,Q115,Q200,Q201,Q202 Q203,Q204,Q205,Q206,Q207 Q208,Q209,Q210,Q211
25381-301	ZTX313 Transistor	2	Q3,Q103
25381-304	ZTX510 Transistor	6	Q6,Q8,Q16,Q106,Q108,Q116
25601-007	J309 Transistor	3	F1,F101,F200
27104-203	LM393 Int. Circuit	1	U201
27106-002	LM358N Int. Circuit	1	U300
27106-501	LF351N Int. Circuit	2	IC1,U101
27106-507	TL074 Int. Circuit	1	U210
27106-508	TL072 Int. Circuit	1	U212
27124-001	LM733 Int. Circuit	2	IC2,U102
27156-010	CD4051 Int. Circuit	1	U206
27156-012	CD4052 Int. Circuit	3	U204,U207,U211
27161-801	ZN404 Int. Circuit	1	D309
27211-102	DS75107 Int. Circuit	1	U200
27156-016	74HC4066 Int. Circuit	2	U3,U103
27266-021	CD4094 Int. Circuit	3	U202,U203,U205
25386-300	TIP31A Transistor	1	Q301
25386-301	TIP32A Transistor	2	Q300,Q302
27160-009	LM7905 Int. Circuit	1	U301

ANALOGUE PLOTTER INTERFACE PCB ASSEMBLY

PART NUMBER	DESCRIPTION	QTY	CIRCUIT REFERENCE
22044-001	Zerohm Link	4	L1,L2,L3,L4
22571-301	4mm. Black Socket (PCB)	5	S1,S2,S3,S4,S5
23180-139	220R 1/3W 5% CF Resistor	1	R13
23180-140	820R 1/3W 5% CF Resistor	4	R1,R2,R3,R4
23180-158	100k 1/3W 5% CF Resistor	4	R8,R9,R10,r12
23180-163	10k 1/3W 5% CF Resistor	1	R11
23203-307	91k 1% 50ppm MF Resistor	1	R6
23203-318	1k 1% 50ppm MF Resistor	2	R17,R18
23203-388	1k3 1% 50ppm MF Resistor	1	R19
23203-391	1k8 1% 50ppm MF Resistor	3	R14,R15,R16
23203-392	180k 1% 50ppm MF Resistor	2	R5,R7
23376-001	100R 10mm Hor. CF Preset	3	PR3,PR4,PR5
23376-509	10k 10mm. Hor Cerm Preset	1	PR2
23376-510	22k 10mm. Hor Cerm Preset	1	PR1
23427-218	330p Ceramic Plate Cap.	1	C3
23557-103	1uF 63V Radial Elec. Cap.	3	C7,C8,C9
23557-110	47uF 10V Radial Elec. Cap	2	C1,C2
23620-006	47nF 63V Polyester Cap.	3	C4,C5,C6
25021-001	1N4148 Diode	1	D1
25341-200	ZTX214 Transistor	1	Q1
25380-251	ZTX239 Transistor	1	Q2
27106-507	TL074 Int. Circuit	1	IC5
27153-801	ZN429E8 Int. Circuit	1	IC2
27156-012	CD4052 Int. Circuit	1	IC6
27156-015	CD4066 Int. Circuit	1	IC4
27161-801	ZN404 Int. Circuit	1	O2
27266-021	CD4094 Int. Circuit	2	IC1,IC3



DSA CALIBRATION PROCEDURE.

NOTE: DO NOT ADJUST ANY PRESET NOT MENTIONED ON THIS PROCEDURE.

- A) Leave the unit switched on for 30 minutes until it has warmed up.
- B) Check power supply voltages.
  - 1. Adjust P300 measured at LK1 to +7V  $\pm$ 50mv.
  - 2. Check voltage at LK3 for -7V  $\pm$ 100mv.
  - 3. Adjust P301 measured at LK4 to +5.05v.
  - 4. Check voltage at LK2 for -5V  $\pm$ 100mv.
- C) With the DSA on HOLD, connect a frequency meter at PIN 6 of 1C450 (74HC14) on the upper PCB, and adjust PR404 to 10MHz.
- D) DC BIAS CH1.  
With the inputs grounded, look at pin 6 of 1C1 for a reading of 0V  $\pm$ 100mV.  
Adjust PR1 if necessary.
- E) Perform "function 78"
- F) Check that both traces are clean and together.
- G) Perform "Set scope", and adjust rear panel preset for 6 divisions exactly.
- H) Perform "Shift Reset"
- I) Set timebase to 200us.
- J) With an input of 6V pk-pk at 50kHz, from an accurate source, adjust PR2 for 6 divisions exactly on the 'scope display.
- K) Move input from CH1 to CH2 and adjust PR102 for 6 divisions exactly.
- L) Check accuracy of both channels at all attenuator settings.

END OF TEST

## FUNCTION OF CALIBRATIONAL ADJUSTMENTS

PR300	SET +7V RAIL.
PR301	SET +5V RAIL.
PR1	SET DC BIAS (CH1)
PR101	SET DC BIAS (CH2)
PR2	SET OVERALL GAIN (CH1)
PR102	SET OVERALL GAIN (CH2)
VC1	AC COMPENSATION. (1V RANGE - CH1)
VC101	AC COMPENSATION. (1V RANGE - CH2)
VC2	AC COMPENSATION. (2V RANGE - CH1)
VC102	AC COMPENSATION. (2V RANGE - CH2)
VC3	AC COMPENSATION. (100mV RANGE - CH1)
VC103	AC COMPENSATION. (100mV RANGE - CH2)
PR3	PULSE RESPONSE AND BANDWIDTH (CH1)
PR103	PULSE RESPONSE AND BANDWIDTH (CH2)
VC4	PULSE RESPONSE AND BANDWIDTH (CH1)
VC104	PULSE RESPONSE AND BANDWIDTH (CH2)
P400	SET SCOPE ADJUSTMENT
P401	NOT USED.
P402	ADC DROP-OUT ADJUSTMENT
P403	REPEAT MODE ADJUSTMENT
P404	10MHZ CLOCK ADJUSTMENT